

III. DEA-P ORGANIZATIONAL MISSIONS

DEA-PA ORGANIZATIONAL MISSIONS

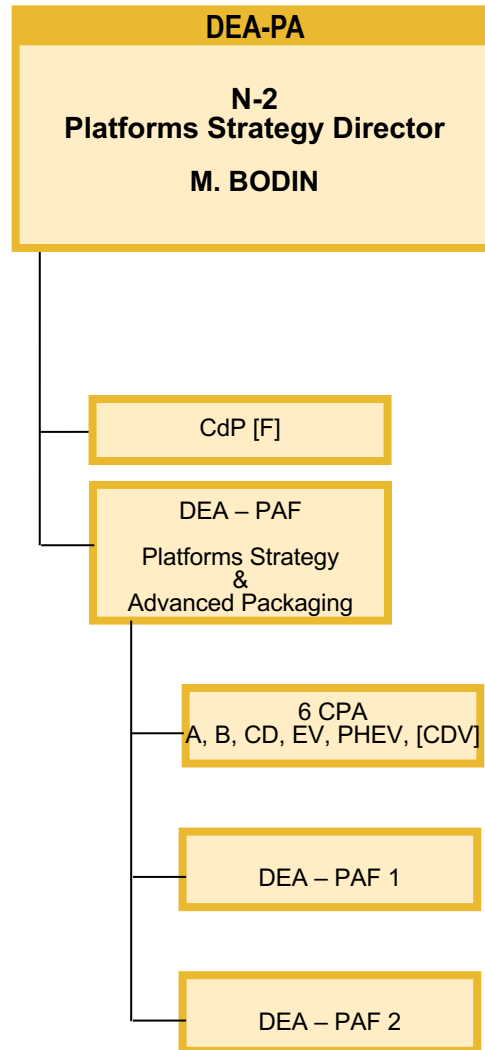

Missions

To contribute to the sustainable profitability of vehicle projects through the platform development:

- by proposing PF scenarios complying with economical playground (cost/ET), in consistency with the plans [E], [V], [T], [U]... and the resources of technical departments.
- by suggesting engineering solutions and accessible technological breakthroughs by indicating the brand image
- by proposing Big Modules road map to secure PF competitiveness and low diversity
- by ensuring the convergence towards the PF Selection, through monitoring technical departments (métiers)
- by ensuring the hand-over to the development team by PF Selection timing.
- by deploying regulatory requirements and creating the demonstration for safety risks control
- by monitoring the PF strategy implementation with development team through PF Book follow up

Deliverables

- Framing Note (Note de Cadrage)
- Milestone technical documents (CPP2 etc.)
- Risk/Opportunity list through QCDP result
- Ki list with technical definition at D-Lot
- Innovation list and associated risks
- Master planning of platform project
- BM strategy
- BM variation plan
- PF Strategy & plan
- PF competitive analysis
- Def Tech (ex. eBOM) data
- DCS chart
- TSC document
- Alliance PF Process
- Full cost commonality ratio